

WANDLITE USAGE

WANDLITE TECHNICAL SHEET

CONTENTS

1. Product Description
2. Health & Safety Information
3. Product Apparatus
4. Accessories
5. Product Specification
6. Operating Instructions
7. Maintenance & Cleaning

1. PRODUCT DESCRIPTION

Wandlite 12V LED Lamp

- Class III luminaire.
- Diffused lighting.
- Long lasting LED lights, 65,000 – 70,000 hours.
- Able to link maximum of two Wandlites together.
- Robust and lightweight construction.
- No flicker.
- Versatile mounting options.

2. HEALTH & SAFETY INFORMATION

Read these instructions and manufacturers warnings before operating.

- Only use Wandlite with recommended power supply, mains power lead, link cable and 2 way splitter cable.
- Do not continue to use product if it becomes damaged or is malfunctioning.
- Do not attempt repairs yourself. If damaged or malfunctioning the product should be disposed of responsibly.
- Keep out of the reach of small children and animals. THIS IS NOT A TOY.
- Do not insert foreign objects into the Wandlite power sockets.
- For internal use only, do not expose to water.
- Do not connect any other devices to the power supply.
- Instructions must be followed to ensure correct operation.
- Ensure that Wandlite power sockets are clean before use.
- Power supply unit must not be suspended from the Wandlite.
- The Wandlite must only be mounted by means shown in operating instructions.
- Do not use Wandlite power sockets to power any other devices

3. PRODUCT APPARATUS

- A. Wandlite
- B. Mains Power lead
- C. 2A / 5A / 8A Power Supply

****all transformers include a mains power lead**

4. ACCESSORIES

- D. Hanger
- E. Reflector
- F. Link Cable
- G. 2 Way Splitter Cable
- H. Stirrup Hanger
- I. Mounting Clip

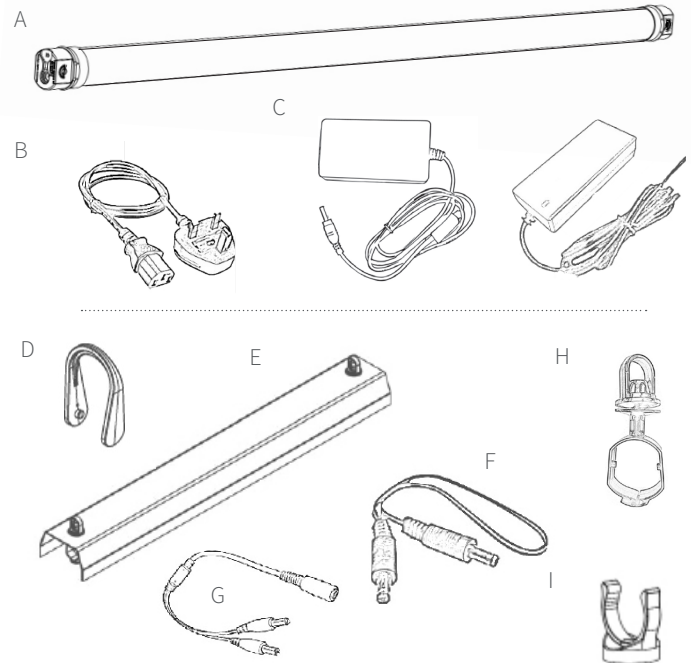

5. PRODUCT SPECIFICATION

1000 WANDLITE - SINGLE UNIT AS SHOWN IN FIGURE A	
Brightness	1713 Lumen Approx
Power consumption	23.8W
DC power input	12V 1.5A
Fuse	5A resettable
Operating temperature	25°C
Operating humidity	40-90%
Diameter	39mm
Length	1000mm
Weight of Wandlite	272g
IP Rating	IP65
Kelvin Rating	6000
Flammability Rating	UL94 V-0

6. OPERATING INSTRUCTIONS

A. Safe operating instructions

- Ensure correct power supply is being used.
- Ensure Wandlite power sockets are clean.
- Always fully insert power supply plug into the Wandlite power socket.
- Ensure cables are tidy and secured to prevent hazards.

B. Using Hangers

- Wandlite can be hung vertically or horizontally.
- Refer to figures 1 and 2 for vertical hanging, figure 3 for horizontal hanging.
- Clip Hangers into slots either side of the Wandlite end cap.

C. Using 2A power supply:

- Refer to figure 4.
- Plug 12V 2A power supply into mains supply. Do not switch on.
- Insert power plug into Wandlite power socket.
- Switch on power at mains

8A power supply - 2 Way Splitter Cable-

- Refer to figure 5.
- Plug 12V 8A power supply into mains supply. Do not switch on.
- Insert power plug into splitter cable socket.
- Insert splitter cable plugs into one power socket of each Wandlite.
- A single additional Wandlite can be connected in line to each Wandlite with use of Link cable.
- Insert a Link cable plug into power socket at opposite end of Wandlite/s.
- Insert the remaining end plug of the Link Cable into power socket at end of second Wandlite to form a linked pair.
- Switch on power at mains.
- A maximum of 4 Wandlites in 2+2 layout can be connected in this way (see figure 5).

WARNING - Do not attempt to link more than the stated maximum number of Wandlites. Only link a maximum of 2 Wandlites in line.

7. MAINTENANCE & CLEANING

- If the product becomes dirty, unplug Wandlite from 12V power supply and wipe with a cloth dampened with water. Do not use any other cleaning substances.
- Be sure to secure Rubber bungs.
- Do not allow any water into the power sockets.

MOUNTING CLIPS

- Refer to figure 6
- Use 2 mounting clips minimum.
- Mounting Clips to be set at correct distance apart so that they are able to clamp onto the 35mm diameter tube.
- User to secure Mounting Clips to mounting surface using suitable fixings.
- Wandlite inserted and removed from wall clips by hand.

FIG. 1

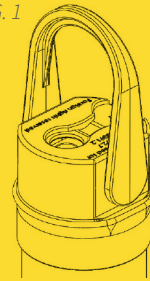

FIG. 2

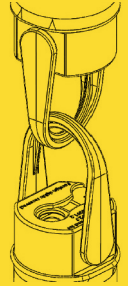

FIGURE 3

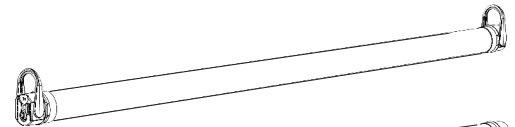

FIGURE 4

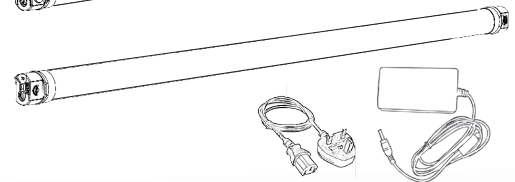

FIGURE 6

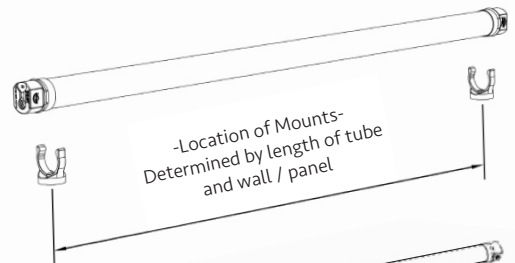
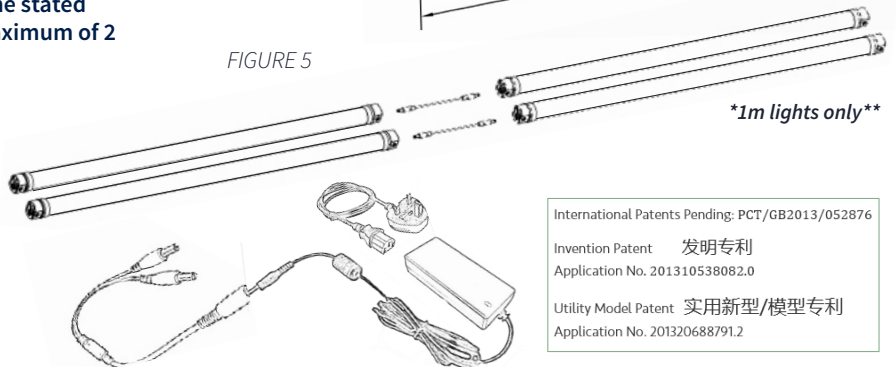

FIGURE 5



International Patents Pending: PCT/GB2013/052876

Invention Patent 发明专利
Application No. 201310538082.0

Utility Model Patent 实用新型/模型专利
Application No. 201320688791.2